

324G

Skid Steer



JOHN DEERE





324G SKID STEER

TAKE IT ALL IN STRIDE

Over the years, we've relied on owners and operators like you to weigh in on what makes our equipment work for the work you do. Inspired — and challenged — by what you pointed out, we've reimagined our compact 324G Skid Steer in some pretty big ways. We added more power under the hood. Maximized lift height, dump clearance, reach, stability, and breakout force. And amped-up the options to include LED side lighting, rearview camera, ride control, and high-flow auxiliary hydraulics. All so you can effortlessly tackle your toughest tasks and come back for more.

FEATURES



It's easy to take control

Electrohydraulic (EH) ISO-pattern joystick controls that allow customized machine operations based on operator preference are standard on the 324G.

Power lifter

Vertical-lift boom combines height and reach at the top of the lift path with outstanding stability, making the 324G ideal for stacking and truck-loading applications.

Load warrior

Height to hinge pin of 10 feet 6 inches enables the 324G to easily load tandem-axle dump trucks, fill hoppers, and feed mixers. Additional reach to truck-bed height comes in handy for moving pallets of pavers or other weighty materials.

The force factor

Extreme pushing power and bucket breakout forces deliver the tractive effort and leverage to carve out clay, handle heavy loads, and plow through piles.

Get in the speed zone

Standard two-speed transmission delivers travel speeds of up to 12 miles per hour, for rapid work cycles that push productivity even further.



RELIABLE



PRODUCTIVE

Packed for productivity

Low center of gravity, 34-degree bucket rollback, optional ride control, and optional hydraulic self-leveling help keep forks loaded and buckets full. Add capacity with up to three sets of rear counterweights.

Big ideas that deliver

Large cab entryway with swing-out door, generous foot- and legroom, sealing and pressurization to minimize dust and noise, and adjustable high-back sculpted seat optimize operator comfort. Overhead panel conveniently puts machine data on the left and control switches on the right. Easy-to-read LCD monitor reveals a wealth of vital operating info and advanced diagnostics.

Seeing is believing

Clear sightlines to the cutting edge and bucket corners, above and below the lift arms, and the jobsite ahead and behind instill confidence in close quarters. Optional LED side lighting and rearview camera further enhance visibility.

Within easy reach

Tilt the hood up for convenient ground-level access to the dipstick, filters, and fuel and fluid fills. Neat freaks and rental yards can appreciate the convenient cab-footwell access that helps speed cleaning.

Work your connections

Equip your skid steer with your choice of over 100 available John Deere attachments to expand the flexibility of your operation. Increased auxiliary hydraulic flow and power compared to previous models boosts attachment performance. Add a snow blower, snow pusher, or angle broom to make quick work of winter's white stuff.



324G SKID STEER



**SWITCHING ATTACHMENTS
ENABLES VERSATILITY IN
ANY WEATHER OR SEASON**

Safety first

Standard personal-protection features include in-cab-activated boom lock and triple-interlock system that detects the presence of the operator to help keep harm's way at bay.

Remote diagnostics and support

To maximize uptime and lower costs, JDLink™ connectivity provides machine location, utilization data, and alerts to help you maximize productivity and efficiency. JDLink also enables John Deere Connected Support™. Dealers use Expert Alerts based on data from thousands of connected machines to proactively address conditions that may otherwise likely lead to downtime. Your dealer can also monitor machine health and leverage remote diagnostics and programming capability to further diagnose problems and even update machine software without a time-consuming trip to the jobsite.*

*Availability varies by region. Options not available in every country.



324G SKID STEER SPECIFICATIONS

Engine		324G			
Manufacturer and Model	Yanmar 4TNV98CT	Yanmar 4TNV98T	Manufacturer and Model <i>(continued)</i>	Yanmar 4TNV98CT	Yanmar 4TNV98T
Non-Road Emission Standard	EPA Final Tier 4 (FT4)/EU Stage IV	EPA Interim Tier 4 (IT4)/EU Stage IIIA	Non-Road Emission Standard <i>(continued)</i>	EPA FT4/EU Stage IV	EPA IT4/EU Stage IIIA
Cylinders	4	4	Displacement	3.3 L (203 cu. in.)	3.3 L (203 cu. in.)
Gross Rated Power (ISO 14396)	55.0 kW (74 hp) at 2,500 rpm		Rated Engine Speed	2,500 rpm	2,500 rpm
Net Peak Power (SAE J1349 / ISO 9249)	52.5 kW (70 hp) at 2,500 rpm		Torque Rise	34% at 1,800 rpm	36% at 1,800 rpm
Peak Torque	280 Nm (207 ft.-lb.) at 1,800 rpm		Aspiration	Turbocharged	Turbocharged
			Air Cleaner	Dry dual element	Dry dual element
Cooling					
Fan Type	Variable-speed hydraulic drive standard / reversing fan drive optional				
Powertrain					
Type	Hydrostatic-manual or electrohydraulic; 4 – 80 heavy-duty (HD) continuous-loop chain				
Travel Speed, 2 Speed, High, Standard	19.3 km/h (12 mph)				
Axles					
	Induction-hardened, 1-piece forged axle shafts with maintenance-free oil-bath lubrication of inner and outer axle bearings				
Maximum Axle Torque	6771 Nm (4,994 lb.-ft.)				
Tractive Effort	3220 kgf (7,491 lbf)				
Final Drive					
	High-strength, adjustment-free chains				
Brakes					
	Integral, automatic, spring-applied, hydraulically released, wet-disc park brake				
Hydraulics					
Pump Flow			Hydraulic Horsepower Flow (calculated)		
Standard	78 L/m (21 gpm)		Standard	31 kW (42 hp)	
Total With High-Flow Option	120 L/m (32 gpm)		High Flow	47 kW (64 hp)	
System Pressure at Couplers	23 787 kPa (3,450 psi)		Auxiliary Hydraulics	Connect-under-pressure with flat-faced couplers	
Cylinders					
Type	John Deere heat-treated, chrome-plated polished cylinder rods, hardened steel (replaceable bushings) pivot pins				
Electrical					
Voltage	12 volt				
Battery Capacity	750 CCA standard / 925 CCA optional				
Alternator Rating	75 amp				
Lights					
	Halogen: 2 front and 1 rear standard / deluxe LED (4 front and 1 rear) optional				
Operator's Station					
	ROPS (ISO 3471) / FOPS (ISO 3449) structure with quick-pivot standard				
Tires/Wheels					
Standard Tire Size	12 x 16.5 12 PR SKS				
Serviceability					
Refill Capacity					
Fuel Tank	79 L (21 gal.)				
Operating Weight					
Base Machine	3496 kg (7,700 lb.)				
Machine Dimensions					
A Length Without Bucket	2.85 m (112.3 in.) (9 ft. 4 in.)				
B Length					
With Foundry Bucket	3.46 m (136.3 in.) (11 ft. 4 in.)				
With Construction Bucket	3.71 m (146.1 in.) (12 ft. 2 in.)				
C Width Without Bucket	1.70 m (67.0 in.) (5 ft. 7 in.)				
D Height to Top of ROPS	2.06 m (81.1 in.) (6 ft. 9 in.)				
E Height to Hinge Pin	3.20 m (126.0 in.) (10 ft. 6 in.)				
F Dump Height					
With Foundry Bucket	2.59 m (102.1 in.) (8 ft. 6 in.)				
With Construction Bucket	2.43 m (95.5 in.) (8 ft. 0 in.)				
G Dump Reach					
With Foundry Bucket	0.76 m (29.9 in.)				
With Construction Bucket	0.95 m (37.3 in.) (3 ft. 1 in.)				
H Wheelbase	1.12 m (44.2 in.) (3 ft. 8 in.)				
I Ground Clearance	0.24 m (9.3 in.)				
J Angle of Departure	28 deg.				
K Front Turn Radius With Foundry Bucket	2.02 m (79.6 in.) (6 ft. 8 in.)				
L Dump Angle (full lift height)	41 deg.				
M Bucket Rollback (ground level)	34 deg.				

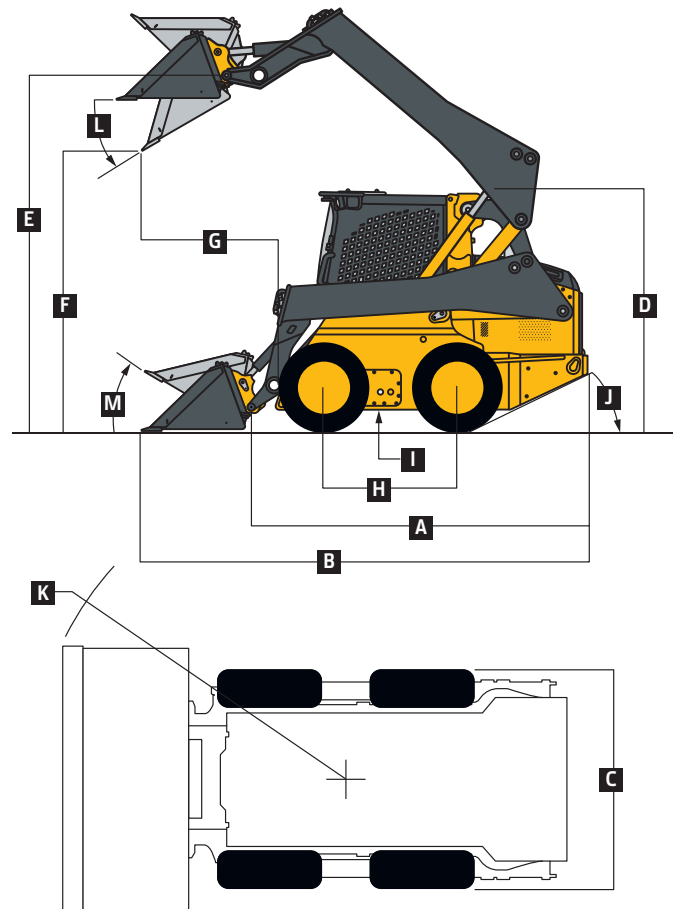

While general information, pictures, and descriptions are provided, some illustrations and text may include product options and accessories NOT AVAILABLE in all regions, and in some countries products and accessories may require modifications or additions to ensure compliance with the local regulations of those countries.

Loader Performance		324G	
Tipping Load	2443 kg (5,380 lb.)	Boom Breakout Force <i>(continued)</i>	
SAE Rated Operating Capacity	1221 kg (2,690 lb.)	With Construction Bucket	2157 kg (4,750 lb.)
With Counterweight	1294 kg (2,850 lb.)	Bucket Breakout Force	
Boom Breakout Force		With Foundry Bucket	3973 kg (8,750 lb.)
With Foundry Bucket	2384 kg (5,250 lb.)	With Construction Bucket	2724 kg (6,000 lb.)

Additional equipment

Key: ● Standard ▲ Optional or special

See your John Deere dealer for further information.

324G Engine

- Meets EPA Final Tier 4/EU Stage IV emissions
- Yanmar 4TNV98CT
- ▲ Yanmar 4TNV98T
- Auto-idle
- Automatic fan tensioner
- Automatic preheat
- Electronic injection system
- ▲ Engine air precleaner kit
- Fuel tank, 79 L (21 gal.)
- John Deere COOL-GARD™ II Extended-Life Engine Coolant
- John Deere Plus-50™ 10w30 initial engine oil fill[‡]
- 4-cylinder 55.0 kW (74 gross hp)/52.5 kW (70 net hp), 3.3-L (203 cu. in.) displacement
- 5-micron primary fuel filter and water separator
- ▲ Cold-weather starting package

Cooling System

- Coolant surge tank
- Variable-speed hydraulically driven fan cooling system
- ▲ Reversing fan drive

Powertrain

- High-strength adjustment-free final-drive chains
- Automatic spring-applied hydraulically released wet-disc park brake
- Wet-disc brakes
- Transmission, 2 speed

Hydraulic System

- John Deere hydraulic cylinders with cushioned boom cylinders
- John Deere heat-treated, chrome-plated cylinder rods with replaceable bushings
- Connect-under-pressure auxiliary couplers
- Quick-check hydraulic fluid-level sight glass
- 1,000-hour, 5-micron hydraulic filter
- ▲ High-flow hydraulics
- Axial-piston hydrostatic pump

Electrical

- Automatic engine/hydraulic shutdown protection system
- Auxiliary hydraulics operator-presence system
- Courtesy lighting

324G Electrical *(continued)*

- Deluxe instrumentation EMU with: Operator-selectable monitoring – Hour meter, engine rpm, battery voltage, diagnostics, EMU configuration, engine coolant temperature, hydraulic oil temperature / LED warning indicators – Glow plug, seat switch, seat belt, door open, auxiliary hydraulics, park brake engaged, 2-speed engaged, stop, low engine oil pressure, engine coolant over-temperature, battery not charging, air filter restriction, and hydraulic filter restriction
- ▲ Deluxe LED lighting package with additional cab-integrated side lights (2)
- Front and rear halogen work lights
- Triple-interlock operator-presence control system
- Backup alarm
- Battery, 750 CCA
- ▲ Battery, 925 CCA
- ▲ Hazard warning lights
- ▲ Strobe light, amber
- Horn

Operator's Station

- Deluxe cab headliner
- Electrohydraulic (EH) ISO-pattern joystick controls
- ▲ ISO-H switchable joystick controls and EH joystick performance package*
- Keyless-start sealed-switch module with integrated anti-theft system and operator memory preference settings
- Electronic push-button auxiliary controls
- Pull-down adjustable lap bar
- Quick-pivot ROPS
- Rear window
- Removable top window
- ▲ Sliding/locking/removable glass side windows
- ROPS/FOPS operator structure
- ▲ Glass cab enclosure
- Seat belt, 51 mm (2 in.), retractable
- ▲ Shoulder belt, 51 mm (2 in.) or 76 mm (3 in.)
- ▲ Severe-duty cab door and wiper system
- Water-shedding deluxe vinyl suspension seat
- ▲ Air-ride cloth, heated seat

324G Operator's Station *(continued)*

- ▲ Air-ride vinyl seat
- 12-volt power port / Dome light / Cargo storage / Beverage holder
- ▲ Air conditioning with heater/defroster
- ▲ AM/FM radio with auxiliary input and Bluetooth® for audio streaming
- ▲ Floor mat with left footrest
- Rearview mirror
- ▲ Rearview camera

Loader

- In-cab boom lockout to secure loader before exiting seat
- Patented John Deere Quik-Tatch™ (no grease required)
- ▲ Power Quik-Tatch
- Patented John Deere vertical-lift boom
- Hydraulic self-leveling on/off
- ▲ Ride control

Other

- Convenient front and rear tie-downs
- Environmental drains for all fluid reservoirs
- 12 x 16.5 12 PR SKS
- ▲ Chrome exhaust stack
- ▲ Engine oil/hydraulic fluid-sampling kit
- ▲ Forestry protection packages
- ▲ Heavy-duty rear grille
- ▲ Rear counterweights (available in sets of 1, 2, or 3), 78 kg (172 lb.) (each set)
- ▲ Single-point lift kit
- ▲ SMV sign kit
- ▲ Spare tire and wheel
- ▲ Tire options: SKS Extra-Wall, Galaxy Beefy Baby III, Galaxy Hulk, and Brawler Solid-Flex
- ▲ JDLINK™ wireless communication system (available in specific countries; see your dealer for details)

[‡]500-hour engine oil-change intervals when John Deere Plus-50 oil and John Deere oil filter are used.

*EH joystick performance package features switchable accelerator/decelerator, selectable propel speeds, creep control, boom- and bucket-speed settings, and 12-volt 3- and 14-pin attachment-control harness with dash-mounted 4th-function rocker switch.

While general information, pictures, and descriptions are provided, some illustrations and text may include product options and accessories NOT AVAILABLE in all regions, and in some countries products and accessories may require modifications or additions to ensure compliance with the local regulations of those countries.

Net engine power is with standard equipment including air cleaner, exhaust system, alternator, and cooling fan, at standard conditions per SAE J1349 and DIN 6270B, using No. 2-D fuel at 35 API gravity. Gross power is without cooling fan. Specifications and design subject to change without notice. Wherever applicable, specifications are in accordance with SAE standards. Except where otherwise noted, these specifications are based on a unit with standard equipment, full fuel tank, and 79-kg (175-lb.) operator.



DKAGSS324 (22-10)

 **JOHN DEERE**